

V15000-V30000-V100000

MOUNTING KIT for COMPRESSION-LOW PROFILE load cells

LAUMAS®
ELETTRONICA

Series load cells: **CBL - CBX**

Application range from 15000 to 100000 kg



MAX STATIC LOAD kg	FOR LOAD CELLS	NET WEIGHT OF MOUNTING KIT (kg)	CODE
30000	CBL (15000 kg) - CBX (30000 kg)*	9	V15000
50000	CBL (30000 kg) - CBX (50000 kg)*	17.5	V30000
100000	CBL (50000 kg) - CBL (100000 kg)	33.5	V100000

Load cell not included.

DESCRIPTION

- AISI 304 stainless steel upper and lower plates.
- AISI 304 stainless steel laminas against lateral forces.
- Anti-tilt system consists of two threaded bars with self-locking nut.

HORIZONTAL CONSTRAINERS
ORIENTATION
IN STRUCTURE WITH
3-POINTS SUPPORT

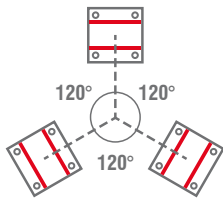

HORIZONTAL CONSTRAINERS
ORIENTATION
IN STRUCTURE WITH
4-POINTS SUPPORT

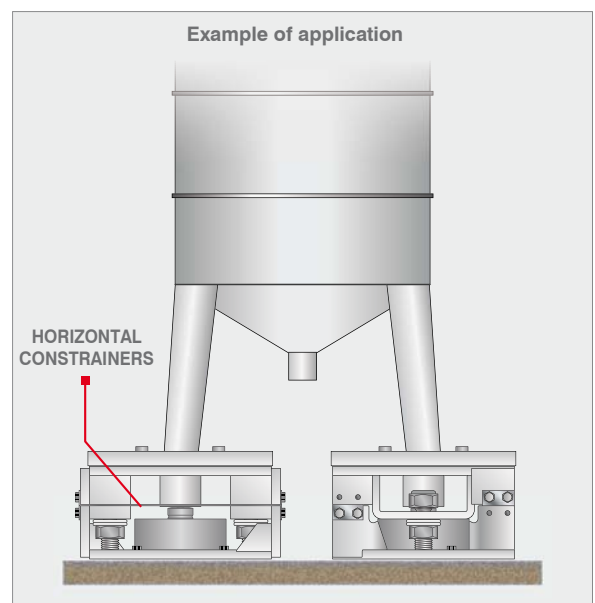
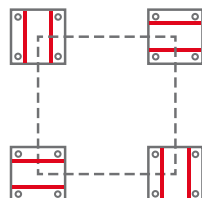

COMPLEMENTARY ACCESSORIES

DESCRIPTION	CODE
 * AISI 304 stainless steel adapter for CBX load cells: <ul style="list-style-type: none"> - V15000 Ø110x6 mm - V30000 Ø126x9 mm - V100000 Ø165x29 mm 	ADAT100CBX15T ADAT126CBX30T ADAT165CBX50T

V15000-V30000-V100000

MOUNTING KIT for COMPRESSION-LOW PROFILE load cells

LAUMAS®
ELETTRONICA

DIMENSIONS AND TECHNICAL SPECIFICATIONS

Upper and lower plates **2** must rest completely on not deformable surfaces. To ensure the stability of the structure, the system designer must predict any further precaution against side shifts and anti-tilt in function of: knocks and vibrations, wind effect, seismic conditions and hardness of support structure.

- Install the weighed system using only the mounting kit without the load cell **1** and inserting in its place a piece of pipe (1-2 mm higher than the load cell).
- To finish the installation (weldings, etc.), remove the piece of pipe and then removing the bolts to fix the the load cell **7** insert the load cell **1** in mounting kit.
- Connect lower and upper plates **2** to the earthing system then loosen nuts **5**; erify that the threaded bar **4** slides into the hole; turn anti-tilt nuts **6** to a distance of 1 mm from plate.
- Tighten the three bolts to fix the load cell **7**.

	A	B	C	D	E	F	G	H	I	L	M	Weight
V15000	102	10	200	160	10	47	20	M12x1.75	Ø17	M20x2.5	40	9 kg
V30000	132	12	250	185	12	70	32.5	M18x2.5	Ø20	M24x3	60	17 kg
V100000	155	15	320	250	15	95	35	M20x2.5	Ø23	M30x3.5	70	34 kg

Dimensions (mm)

Upper plate

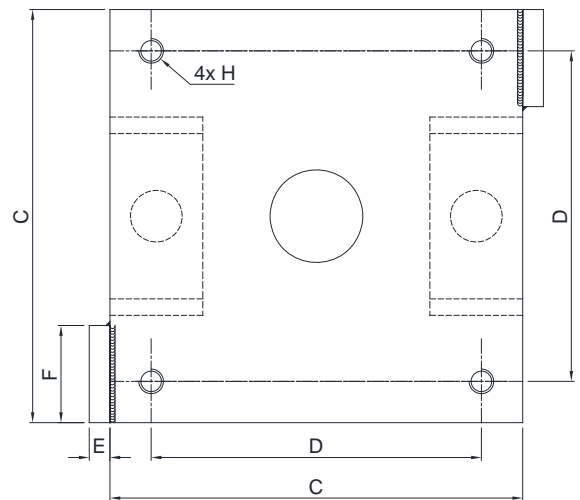

Lower plate

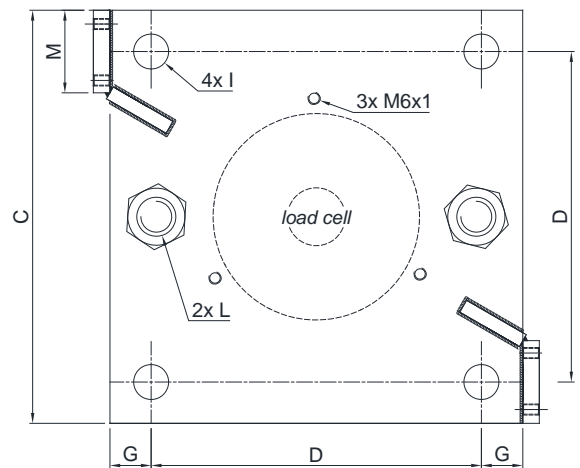

- 1 Load cell.
- 2 AISI 304 stainless steel upper and lower plates.
- 3 AISI 304 stainless steel laminas with horizontal constrainer function.
- 4 Threaded bar.
- 5 Nut to be used as jack.
- 6 Anti-tilt self-locking nut.
- 7 M6 bolts to fix the load cell.

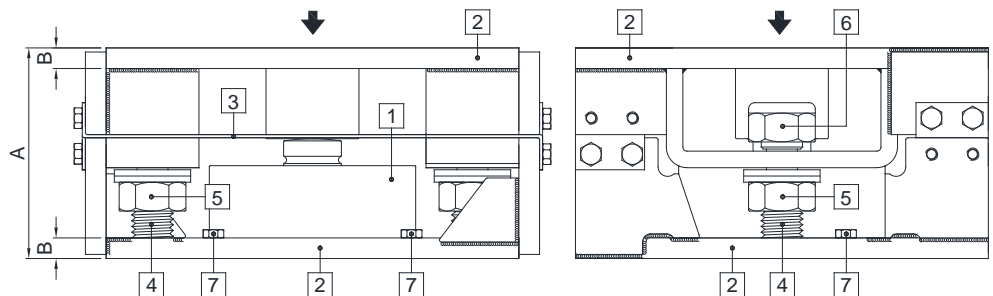

The Company reserves the right to make changes to the technical data, drawings and images without notice.